



Controlled Dehumidification

5931 Ford Court Brighton, MI 48116 • 810.229.7900

Fax: 810.229.7908 • sales@ctrdh.com • ctrdh.com

MS-2400/1000 Hi/Lo Mobile-Dry Units

<u>Model</u>	<u>CFM</u>	<u>"A" Dim.</u>	<u>"B" Dim.</u>	<u>"C" Dim.</u>	<u>Weight</u>
CDH-R-126-2.0	2400/1,000*	91 5/8"	35"	63"	1100 lbs

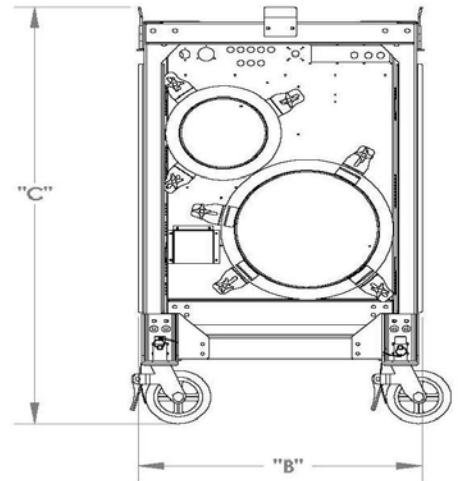
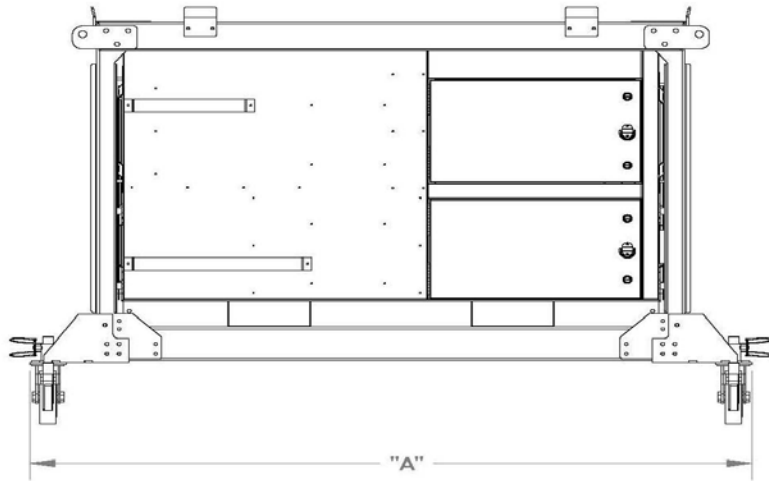

<u>Model</u>	<u>Moisture Removal Lbs/Hr</u> 80°/60% RH	<u>Moisture Removal Gallons/Day</u> 80°/60% RH	<u>Moisture Removal Lbs/Hr</u> 55°/80% RH	<u>Moisture Removal Gallons/Day</u> 55°/80% RH	<u>Moisture Removal Lbs/Hr</u> 40°/80% RH	<u>Moisture Removal Gallons/Day</u> 40°/80% RH	<u>Electric Reactivation FLA Load</u> 460/3/60
CDH-R-126-2.0-Hi	55	158	42	121	25	72	60
CDH-R-126-1.0-Lo	27	79	21	69	12	36	30

Available Accessories:

- (2) Swivel Locking and (2) Fixed Castors
- Lifting and stacking cage
- Remote Humidistat
- Trailer Mounting
- 18" or 20 " Round Supply Connections
- Protective Cage (as shown)

